

GM6

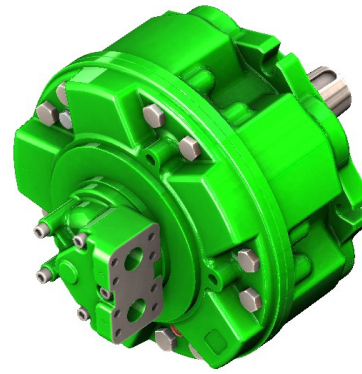

		2100	2500	3000			
Displacement <i>Cilindrata</i>	[cc/rev]	2127	2513	3041			
Bore <i>Alesaggio</i>	[mm]	92	100	110			
Stroke <i>Corsa</i>	[mm]		64				
Specific torque <i>Coppia specifica</i>	[Nm/bar]	33.2	39.2	47.5			
Continuous pressure ⁽¹⁾ <i>Pressione in continuo ⁽¹⁾</i>	[bar]	250	250	250			
Peak pressure <i>Pressione di picco</i>	[bar]	400	350	300			
Peak power ⁽²⁾ <i>Potenza di picco ⁽²⁾</i>	[kW]		170				
Continuous speed ⁽³⁾ <i>Velocità in continuo ⁽³⁾</i>	[rpm]	225	200	175			
Maximum speed <i>Velocità massima</i>	[rpm]	350	300	250			
Approximate weight <i>Peso approssimativo</i>	[kg]	270	<i>unit unità</i>	Motor oil capacity <i>Capacità olio motore</i>	[l]	25	
Maximum casing pressure <i>Pressione massima in carcassa</i>	[bar]	1	continuous <i>continuo</i>	Admissible temperatures <i>Temperature ammissibili</i>	[°C]	-20	minimum <i>minimo</i>
		5	peak <i>picco</i>			+80	maximum <i>massimo</i>

NOTES

(1) Continuous working over 250 bar pressure, please contact the SAI Technical Department.

(1) Per uso continuo sopra i 250 bar contattare l'Ufficio Tecnico SAI.

(2) For higher peak power please contact the SAI Technical Department.

(2) Per potenze di picco maggiori contattare l'Ufficio Tecnico SAI.

(3) For higher continuous speed please contact the SAI Technical Department.

(3) Per velocità in continuo maggiori contattare l'Ufficio Tecnico SAI.

INSTALLATION NOTES

Bolt torque setting <i>Coppia serraggio viti</i>	[Nm]	397,0÷490,0	coarse <i>grosso</i>	419,0÷523,0	fine <i>fine</i>	Suggested bolt type <i>Viti suggerite</i>	M18 12.9
---	------	-------------	-------------------------	-------------	---------------------	--	----------

* Preferred type / * Tipo preferito

DIMENSIONAL DRAWINGS
DISEGNI D'INGOMBRO

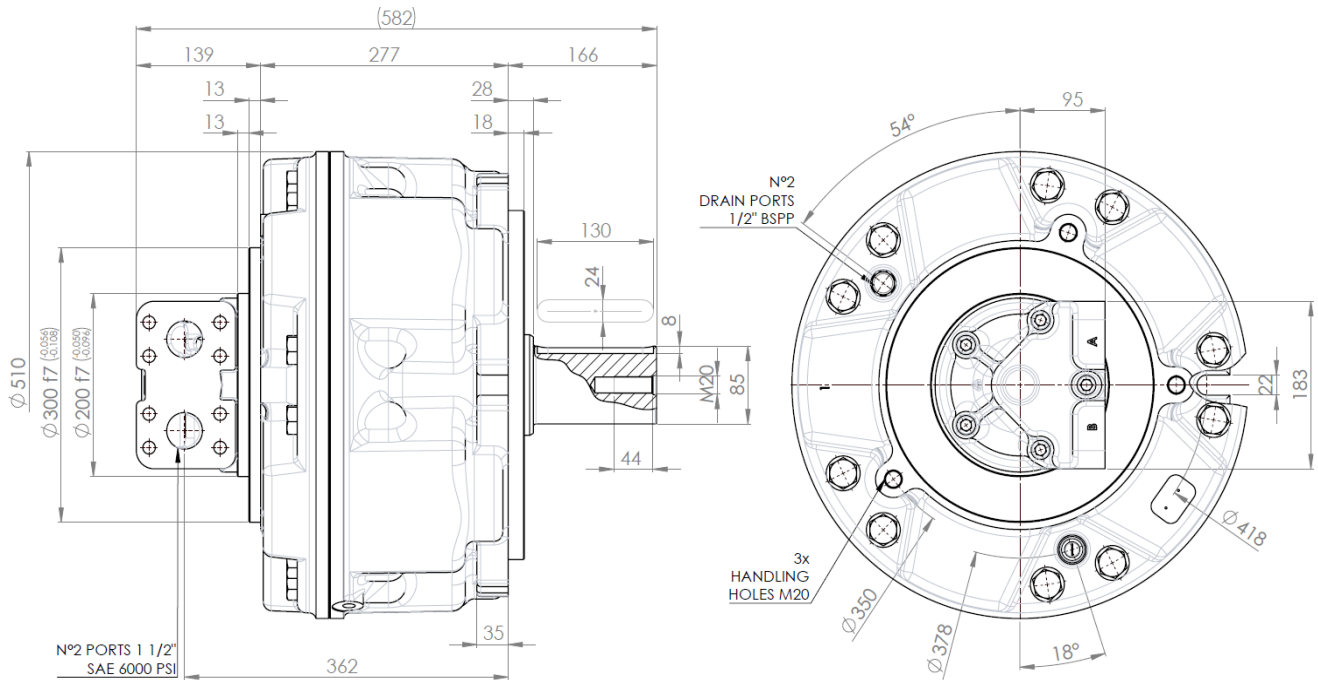

SHAFT OPTIONS
OPZIONI ALBERO

Splined 6/12" PITCH 1*
Calettato BS3550

Internally splined 80x3x25 9
Calettato interno DIN5480

Cylindrical 8
Cilindrico

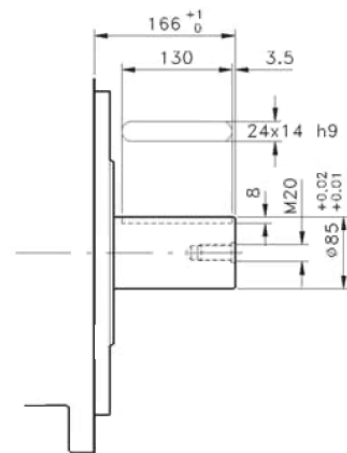
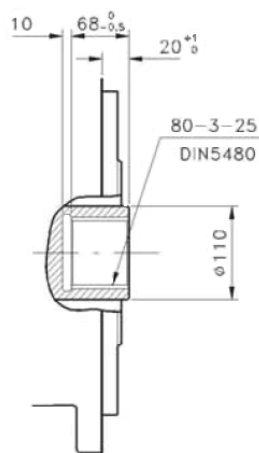
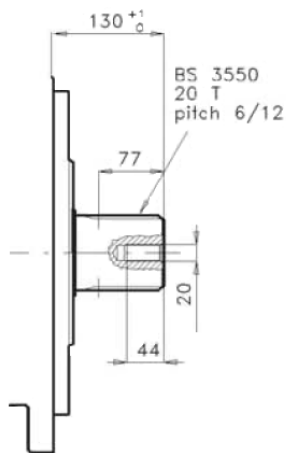

* Preferred type / * Tipo preferito

SPLINE DATI CALETTATURE

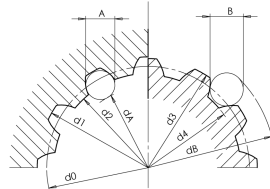

6/12" PITCH Z20 BS3550

d0	Ø 84,600		
d3	Ø 88,000	- 0,047 - 0,170	
d4	Ø 80,000	- 0,480 - 0,070	
B	Ø 8,120		
dB	Ø 97,000	+ 0,082 + 0,030	

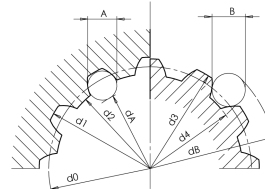

80x3x25 DIN 5480

d0	Ø 75,000		
d1	Ø 80,000	+ 0,870 + 0	H14
d2	Ø 74,000	+ 0,190 + 0	H11
A	Ø 5,2500		
dA	Ø 69,900		H9
d3	Ø 79,400	- 0 - 0,190	h11
d4	Ø 73,400	- 0 - 0,870	h14
B	Ø 6,000		
dB	Ø 85,900		f8

ADAPTORS MANICOTTI

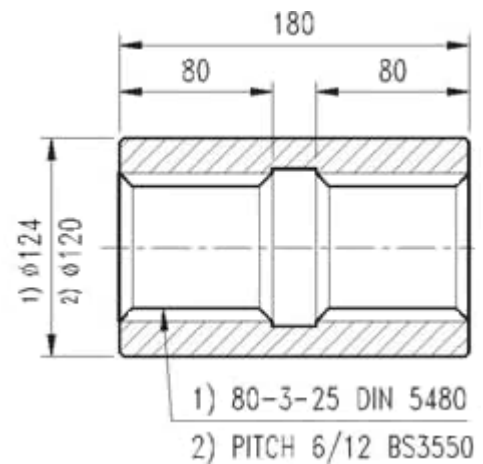

BEARING LIFE VITA CUSCINETTI

The graph refers to the motor with the standard bearings. Note that the average lifetime of a bearing (B_{50} lifetime) is approximately 5 times the B_{10} lifetime.

Il grafico si riferisce ai motori con i cuscinetti standard. Notare che la vita media di un cuscinetto (vita B_{50}) è circa 5 volte superiore alla vita B_{10} .

Chart n°1

Grafico n°1

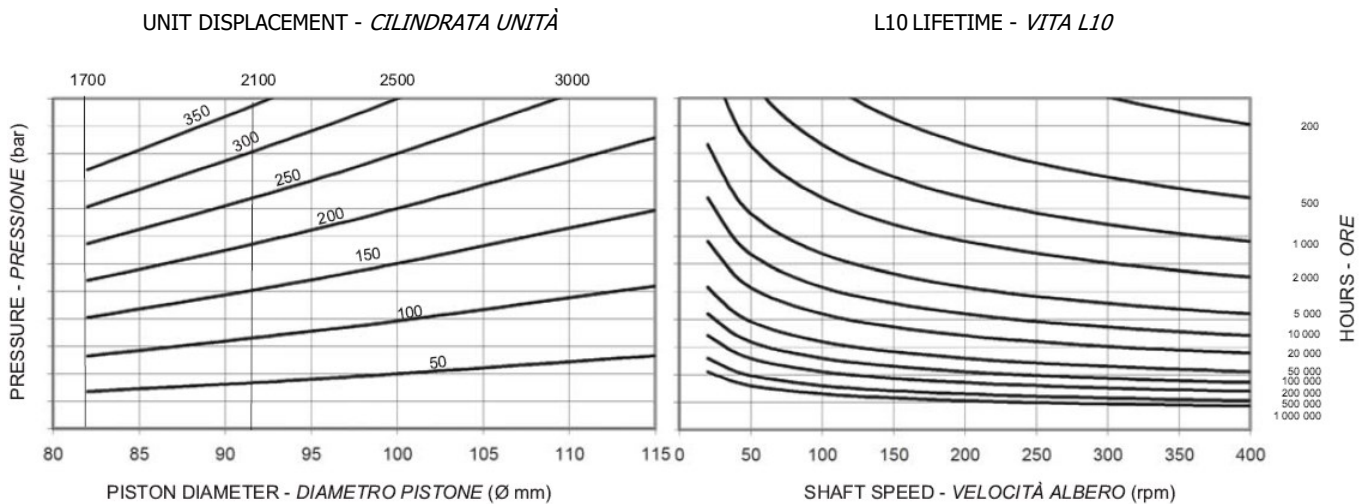

Select the combination pressure-speed-torque to get the estimated bearing life. Use the chart n° 1 of this page.

Selezionare la combinazione pressione-velocità-coppia per ottenere la vita stimata. Utilizzare il grafico n°1 di questa pagina.

Time required bearings:
Loads allowable are calculated for the different phases of the life cycle L_{10} according to ISO 281: 1990.
 L_{10} : duration of the bearing system in millions of revolutions.
 L_{10} can be converted into hours L_{10h} using the formula #.

$$\# \quad L_{10h} = \frac{10^6}{60n} L_{10}$$

n: speed in rpm
n: velocità in rpm

Calcolo durata cuscinetti:
I carichi ammissibili sono calcolati per le diverse fasi del ciclo di vita L_{10} secondo ISO 281:1990.
 L_{10} : durata del sistema di cuscinetti in milioni di giri.
Il valore L_{10} può essere convertito in ore L_{10h} utilizzando la formula #.

ORDER CODES CODICI D'ORDINE

	1		2		3		4		5		6		7		8
GM6	+		+		+		+		+		+		+		+

* Preferred type / * Tipo preferito

1 Displacement	see table	1 Cilindrata	vedere tabella
	1 = male BS 3553 (standard)		1 = maschio BS 3553 (standard)
2 Shaft options	9* = female 80x3x25 DIN 5480 8 = cylindrical keyed	2 Opzioni albero	9* = femmina 80x3x25 DIN 5480 8 = cilindrico con linguetta
3 Bearings	E = reinforced version (standard) U = without shaft seal	3 Cuscinetti	E = versione rinforzata (standard) U = senza tenuta albero
4 Other options	SV = shaft seal protection V = high temperature seals I = case press. relief valve 3 bar	4 Altre opzioni	SV = protezione tenuta albero V = high temperature seals I = valvola di sfiato 3 bar
5 Distributor	see distributor catalogue, D90 standard	5 Distributore	vedere catalogo distributori, D90 standard
6 Distributor options	K = predisposed for tachometer J = with tachometer coupling	6 Opzioni distributore	K = foro predisposizione contagiri J = con attacco contagiri
Direction of rotation	No code = clockwise rotation	Direzione d'uscita	Nessun codice = rotazione oraria
7 (viewed from the output side) with flow in port A, out in port B.	L = anti-clockwise rotation	7 (visto dal lato d'uscita) con portata in ingresso in porta A, uscita in porta B.	L = rotazione anti-oraria

8 Distributor cover orientation	No code = position 1 DM2 = position 2 DM3 = position 3 DM4 = position 4 DM5 = position 5	Orientamento 8 coperchio distributore	Nessun codice = posizione 1 DM2 = posizione 2 DM3 = posizione 3 DM4 = posizione 4 DM5 = posizione 5
--	--	--	---

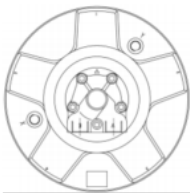

Posizione 1
DM1



Posizione 2
DM2



Posizione 3
DM3

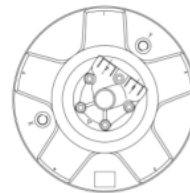

Posizione 4
DM4

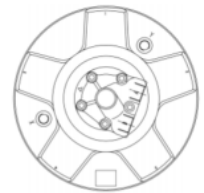

Posizione 5
DM5

Example *Esempio* GM6 2100 9G D90 (standard)

GM6 2100 9GV D90L

(options: high temperature seals and anti-clockwise sense of rotation)

(*opzioni: tenute per alte temperature e direzione d'uscita in rotazione anti-oraria*)